Low Noise, Regulated Charge Pump DC/DC Converter

Features

- Fixed 3.3V \pm 4% Output
- VIN Range: 1.8V to 5V
- Output Current: 100mA
- Constant Frequency Operation at All Loads
- Low Noise Constant Frequency (1.2MHz) Operation
- Automatic Soft-Start Reduces Inrush Current
- Shutdown Current $<1\mu\text{A}$
- Short-Circuit Protection
- No Inductors
- Available in Low Profile 6-Lead SOT23 Package

Applications

- 2 AA Cell to 3.3V
- USB On-The-Go Devices
- White LED Drivers
- Handheld Devices

Description

The 10A45B is a low noise, constant frequency (1.2MHz) switched capacitor voltage doubler. It produce a regulated output voltage from a 1.8V to 5V input with up to 100mA of output current. Low external parts count (one flying capacitor and two small bypass capacitors at VIN and VOUT) make the 10A45B ideally suited for small, battery-powered applications.

The 10A45B have thermal shutdown capability and can survive a continuous short circuit from VOUT to GND. Built-in soft-start circuitry prevents excessive inrush current during start-up.

High switching frequency enables the use of small ceramic capacitors. A low current shutdown feature disconnects the load from VIN and reduces quiescent current to $<1\mu\text{A}$.

The 10A45B is available in the 6-pin SOT23-6.

Typical Applications

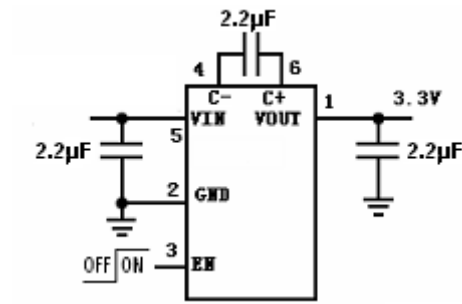

Figure 1: Regulated 3.3V Output

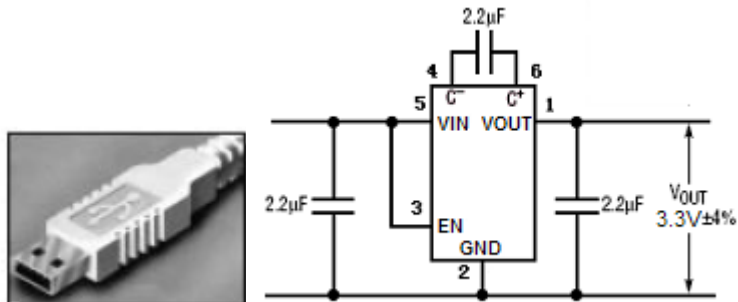
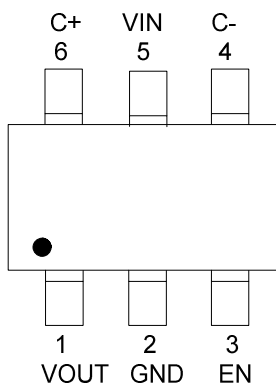

Figure 2: USB Port to Regulated 3.3V Power Supply

Pin Description



PIN NUMBER SOT-23-6	PIN NAME
1	VOUT
2	GND
3	EN
4	C-
5	VIN
6	C+

Absolute Maximum Ratings (Note 1)

- V_{IN} - 0.3V to 6V
- V_{OUT}- 0.3V to 3.5V
- V_{OUT} Short-circuit Duration.....indefinite
- V_{EN}- 0.3V to 6V
- I_{OUT} (Note 2) 150mA
- Operating Temperature Range (Note 3).....- 30°C to 85°C
- Lead Temperature (Soldering 10 sec.)300°C
- Storage Temperature Range- 65°C to 125°C

Note 1: Absolute Maximum Ratings are those values beyond which the life of a device may be impaired.

Note 2: Based on long term current density limitations.

Note 3: The 10A45B are guaranteed to meet performance specifications from 0°C to 70°C. Specifications over the -40°C to 85°C operating temperature range are assured by design, characterization and correlation with statistical process controls.

Electrical Characteristics

The specifications are at $T_A = 25\text{ }^\circ\text{C}$. $V_{IN} = 3.6\text{V}$, $EN = V_{IN}$, $C_{IN} = C_{OUT} = 2.2\mu\text{F}$ unless otherwise noted.

PARAMETER	CONDITIONS	MIN	TYP	MAX	UNITS
Input Voltage Range (V_{IN})		1.8		5	V
Output Voltage Range (V_{OUT})			3.3		V
I_{SHDN} Shutdown Current	$EN = 0\text{V}, V_{OUT} = 0\text{V}$		0.2		μA
No load input current	$I_{OUT} = 0\text{mA}, V_{IN} = 2.7\text{V}$		0.65		mA
Switching Frequency (f_{osc})	$I_{OUT} = 100\text{mA}, V_{IN} = 2.7\text{V}$		1.2		MHz

Typical Performance Characteristics

No Load Supply Current vs. Supply Voltage

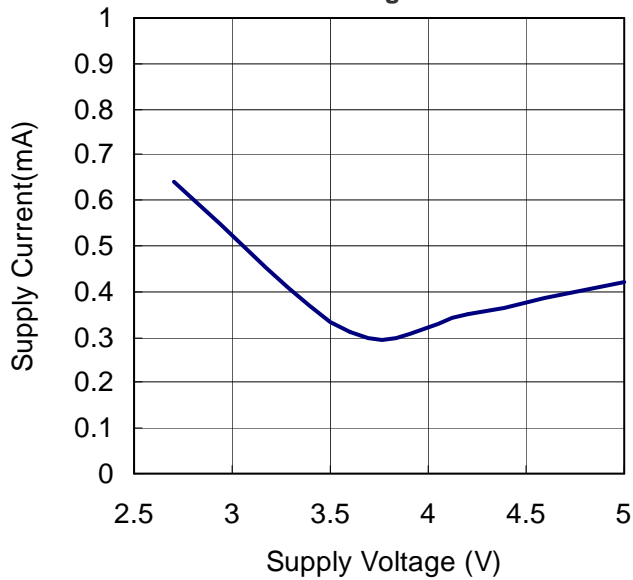

Output Voltage vs. Supply Voltage (IOUT=0A)

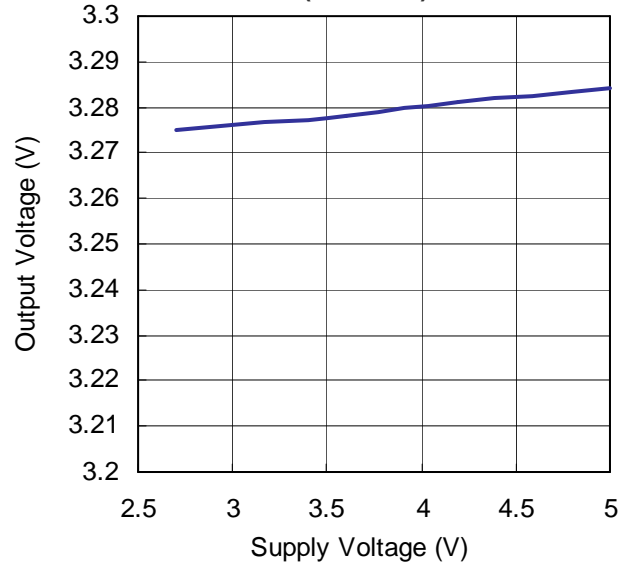

Oscillator Frequency vs. Supply Voltage (IOUT=0A)

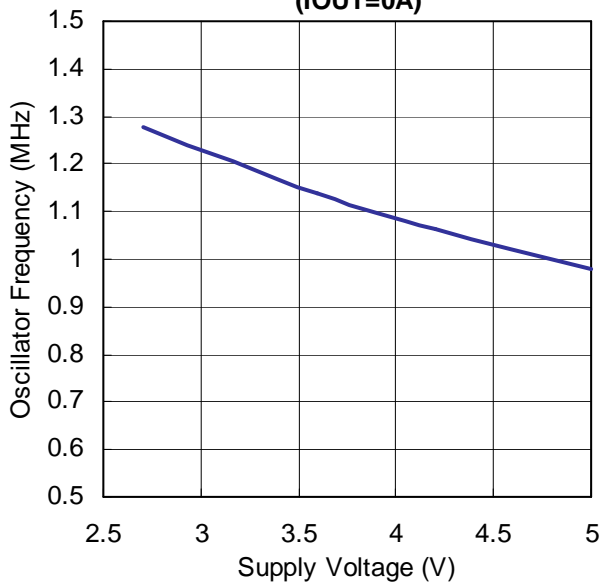

Short Circuit Current vs. Supply Voltage

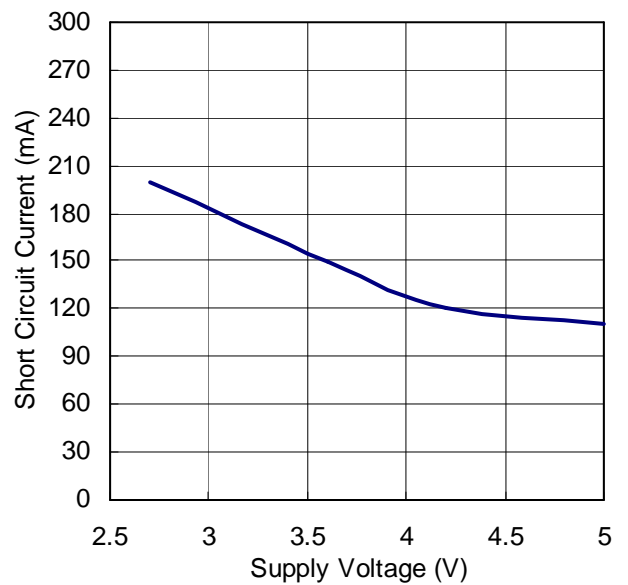

Pin Functions

VOUT (Pin 1): Regulated Output Voltage. VOUT should be bypassed with a low ESR ceramic capacitor providing at least $2.2\mu\text{F}$ of capacitance as close to the pin as possible for best performance.

GND (Pin 2): Ground. These pins should be tied to a ground plane for best performance. The exposed pad must be soldered to PCB ground to provide electrical contact and optimum thermal performance.

EN (Pin 3): Active Low Shutdown Input. This pin must not be allowed to float.

C- (Pin 4): Flying Capacitor Negative Terminal.

VIN (Pin 5): Input Supply Voltage. VIN should be bypassed with a low ESR ceramic capacitor providing at least $2.2\mu\text{F}$ of capacitance as close to the pin as possible for best performance.

C+ (Pin 6): Flying Capacitor Positive Terminal.

Block Diagram

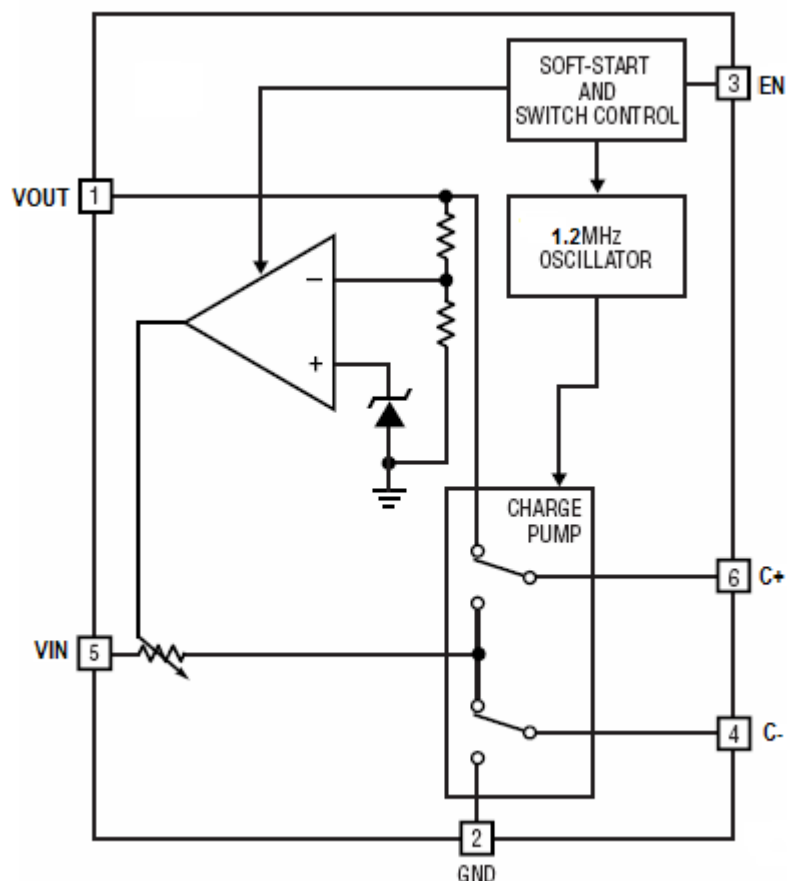

Application Information

Operation

The 10A45B use a switched capacitor charge pump to boost VIN to a regulated output voltage. Regulation is achieved by sensing the output voltage through an internal resistor divider and modulating the charge pump output current based on the error signal. A 2-phase nonoverlapping clock activates the charge pump switches. The flying capacitor is charged from VIN on the first phase of the clock. On the second phase of the clock it is stacked in series with VIN and connected to VOUT. This sequence of charging and discharging the flying capacitor continues at a free running frequency of 1.2MHz (typ).

In shutdown mode all circuitry is turned off and the 10A45B draw only leakage current from the VIN supply. Furthermore, VOUT is disconnected from VIN. The EN pin is a CMOS input with a threshold voltage of approximately 0.8V. The 10A45B is in shutdown when a logic low is applied to the EN pin. Since the EN pin is a high impedance CMOS input it should never be allowed to float. To ensure that its state is defined it must always be driven with a valid logic level.

Short-Circuit Protection

The 10A45B have built-in short-circuit current limiting. During short-circuit conditions, they will automatically limit their output current to approximately 200mA.

VIN, VOUT Capacitor Selection

The style and value of capacitors used with the 10A45B determine several important parameters such as regulator control loop stability, output ripple, charge pump strength and minimum start-up time.

To reduce noise and ripple, it is recommended that low ESR ($< 0.1\Omega$) ceramic capacitors be used for both CIN and COUT. These capacitors should be 2.2uF or greater. Tantalum and aluminum capacitors are not recommended because of their high ESR.

Flying Capacitor Selection

Warning: A polarized capacitor such as tantalum or aluminum should never be used for the flying capacitor since its voltage can reverse upon start-up of the 10A45B. Low ESR ceramic capacitors should always be used for the flying capacitor.

The flying capacitor controls the strength of the charge pump. In order to achieve the rated output current it is necessary to have at least 2.2uF of capacitance for the flying capacitor.

Layout Considerations

Due to its high switching frequency and the high transient currents produced by the 10A45B, careful board layout is necessary. A true ground plane and short connections to all capacitors will improve performance and ensure proper regulation under all conditions. Figure 3 shows an example layout for the 10A45B.

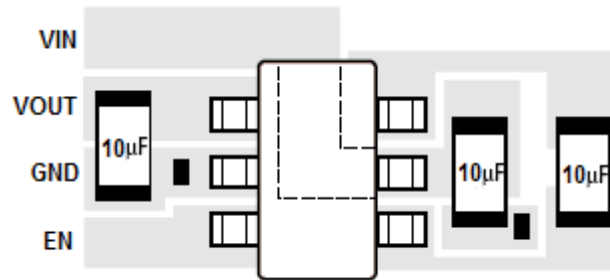
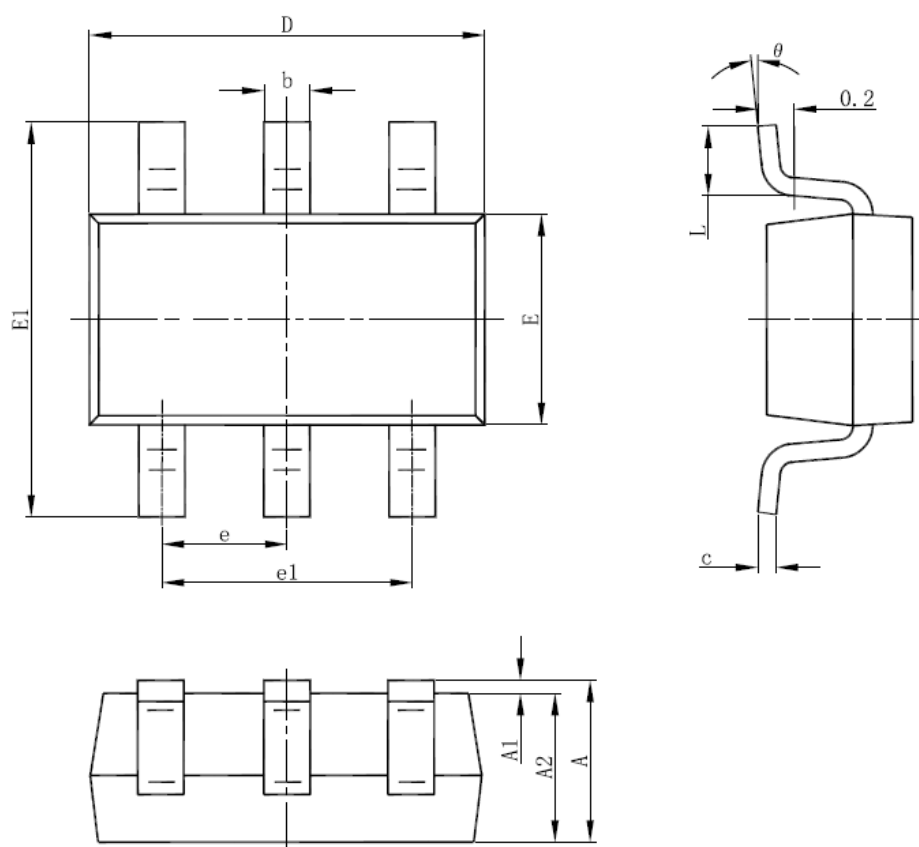

Figure 3: Recommended Layout

Packaging Information

SOT-23-6 Package Outline Dimension



Symbol	Dimensions In Millimeters		Dimensions In Inches	
	Min	Max	Min	Max
A	1.050	1.250	0.041	0.049
A1	0.000	0.100	0.000	0.004
A2	1.050	1.150	0.041	0.045
b	0.300	0.500	0.012	0.020
c	0.100	0.200	0.004	0.008
D	2.820	3.020	0.111	0.119
E	1.500	1.700	0.059	0.067
E1	2.650	2.950	0.104	0.116
e	0.950(BSC)		0.037(BSC)	
e1	1.800	2.000	0.071	0.079
L	0.300	0.600	0.012	0.024
θ	0°	8°	0°	8°